

Absolute encoders – multiturn

Standard electronic multiturn, optical	Sendix F5868 / F5888 (shaft / hollow shaft)	PROFINET IO
---	--	--------------------



The Sendix F58 multiturn with patented Intelligent Scan Technology™ is a particularly high resolution optical encoder without gears and with 100 percent magnetic insensitivity. 43 bits total resolution, shaft up to 10 mm, blind hollow shaft up to 15 mm and certified PROFINET functionality. A minimum cycle time of 250 μs, the PROFIdrive application profile and a web server for FW updates are supported.



Multiturn resolution	Safety-Lock™	High rotational speed	Temperature range	High protection level	High shaft load capacity	Shock / vibration resistant	Magnetic field proof	Reverse polarity protection	Optical sensor

Latest PROFINET functionality

- PROFINET IO, RT, IRT allows integration in applications with different performance requirements.
- Supports the Isochronous Mode, can thus be implemented in networks for hard real-time requirements with clock cycles up to 250 μs.
- Encoder profile V 4.2 with full support of various Profinet features.
- Ideal for highly synchronous applications, such as e. g. axis synchronization.
- Interoperability between many different control and drive manufacturers thanks to the PROFIdrive profile.

Reliable and insensitive

- Sturdy bearing construction in Safety-Lock™ Design for resistance against vibration and installation errors.
- Patented Intelligent Scan Technology™ with all singleturn and multiturn functions on one single OptoASIC - offering the highest reliability, a high resolution up to 43 bits and 100% magnetic field insensitivity.

Absolute encoders – multiturn

Standard electronic multiturn, optical	Sendix F5868 / F5888 (shaft / hollow shaft)	PROFINET IO
---	--	--------------------

Order code	8.F5868	.XXCN.	C1	2	2
Shaft version	Type	a b c d	e		

a Flange

1 = clamping flange, IP65 \varnothing 58 mm [2.28"]
 3 = clamping flange, IP67 \varnothing 58 mm [2.28"]
 2 = synchro flange, IP65 \varnothing 58 mm [2.28"]
 4 = synchro flange, IP67 \varnothing 58 mm [2.28"]
 5 = square flange, IP65 \square 63.5 mm [2.5"]
 7 = square flange, IP67 \square 63.5 mm [2.5"]

b Shaft ($\varnothing \times L$), with flat

1 = 6 x 10 mm [0.24 x 0.39"]
 2 = 10 x 20 mm [0.39 x 0.79"]
 3 = 1/4" x 7/8"
 4 = 3/8" x 7/8"

c Interface / Supply voltage

C = PROFINET IO / 10 ... 30 V DC

d Type of connection

N = 3 x axial M12 connector, 4-pin

e Fieldbus profile

C1 = PROFINET IO

Options – Standard types (available from 1 piece)

V2A
DIN 1.4305
AISI 303

Surface protection salt spray tested with clamping flange IP67 and shaft \varnothing 10 mm:
8.F5868.32CN.C122-C

V4A
DIN 1.4404
AISI 316L

Stainless steel V2A ¹⁾
Order expansion:
8.F5868.XXCN.C122-V2A

V4A
DIN 1.4404
AISI 316L

Stainless steel V4A ¹⁾
Order expansion:
8.F5868.XXCN.C122-V4A

Options – on request (for other flange/shaft combinations)

- Surface protection salt spray tested
- Stainless steel V2A
- Stainless steel V4A

Order code	8.F5888	.XXCN.	C1	2	2
Hollow shaft	Type	a b c d	e		

a Flange

1 = with spring element long, IP65
 2 = with spring element long, IP67
 3 = with stator coupling, IP65 \varnothing 65 mm [2.56"]
 4 = with stator coupling, IP67 \varnothing 65 mm [2.56"]
 5 = with stator coupling, IP65 \varnothing 63 mm [2.48"]
 6 = with stator coupling, IP67 \varnothing 63 mm [2.48"]
 9 = with torque stop, flexible, IP65
 J = with torque stop, flexible, IP67

b Blind hollow shaft (insertion depth max. 30 mm [1.18"])

A = \varnothing 10 mm [0.39"]
 B = \varnothing 12 mm [0.47"]
 C = \varnothing 14 mm [0.55"]
 D = \varnothing 15 mm [0.59"]
 E = \varnothing 3/8"
 F = \varnothing 1/2"

c Interface / Supply voltage

C = PROFINET IO / 10 ... 30 V DC

d Type of connection

N = 3 x axial M12 connector, 4-pin

e Fieldbus profile

C1 = PROFINET IO

Options – Standard types (available from 1 piece)

V2A
DIN 1.4305
AISI 303

Stainless steel V2A ²⁾
Order expansion:
8.F5888.2XCN.C122-V2A

V4A
DIN 1.4404
AISI 316L

Stainless steel V4A ²⁾
Order expansion:
8.F5888.2XCN.C122-V4A

Options – on request (for other flange/hollow shaft combinations)

- Surface protection salt spray tested
- Stainless steel V2A
- Stainless steel V4A

1) Only in conjunction with flange **a** = 3 or 4 and shaft **b** = 1 or 2.
 2) Only in conjunction with flange **a** = 2 and hollow shaft **b** = B or D.

Absolute encoders – multiturn

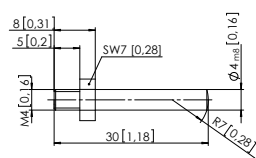
Standard electronic multiturn, optical		Sendix F5868 / F5888 (shaft / hollow shaft)		PROFINET IO	
Mounting accessory for shaft encoders				Order no.	
Coupling	bellows coupling ø 19 mm [0.75"] for shaft 6 mm [0.24"]			8.0000.1102.0606	
	bellows coupling ø 19 mm [0.75"] for shaft 10 mm [0.39"]			8.0000.1102.1010	
Mounting accessory for hollow shaft encoders Dimensions in mm [inch]				Order no.	
Torque pin, ø 4 mm for flange with spring element (flange type 1)	with fixing thread			8.0010.4700.0000	
					
Cables and connectors				Order no.	
Preassembled cables	M12 male connector with external thread, 4-pin, D coded, straight single-ended 2 m [6.56'] PUR cable	port 1 + port 2		05.00.6031.4411.002M	
	M12 male connector with external thread, 4-pin, D coded, right-angle single-ended 2 m [6.56'] PUR cable	port 1 + port 2		05.00.6031.4511.002M	
	M12 female connector with coupling nut, 4-pin, A coded, straight single-ended 2 m [6.56'] PUR cable	power supply		05.00.6061.6211.002M	
	M12 female connector with coupling nut, 4-pin, A coded, right-angle single-ended 2 m [6.56'] PUR cable	power supply		05.00.6061.6311.002M	
Connectors	M12 male connector with external thread, 4-pin, D coded, straight (metal)	port 1 + port 2		05.WASCSY4S	
	M12 male connector with external thread, 4-pin, D coded, right-angle (metal)	port 1 + port 2		8.0000.5128.0000	
	M12 female connector with coupling nut, 4-pin, A coded, straight (plastic)	power supply		05.B8141-0	
	M12 female connector with coupling nut, 4-pin, A coded, right-angle (plastic)	power supply		05.B8241-0	

Further Kübler accessories can be found at: kuebler.com/accessories

Further Kübler cables and connectors can be found at: kuebler.com/connection-technology

Absolute encoders – multiturn

Standard electronic multiturn, optical	Sendix F5868 / F5888 (shaft / hollow shaft)	PROFINET IO
---	--	--------------------

Technical data

Mechanical characteristics	
Max. speed	9000 min ⁻¹ (short-term – 10 min) 6000 min ⁻¹ (continuous)
Starting torque at 20 °C [68 °F]	< 0.01 Nm
Moment of inertia	shaft version 3.0 x 10 ⁻⁶ kgm ² hollow shaft version 6.0 x 10 ⁻⁶ kgm ²
Load capacity of shaft	radial 80 N axial 40 N
Weight	approx. 0.45 kg [15.87 oz]
Protection acc. to EN 60529	IP65, IP67
Working temperature range	-40 °C ... +80 °C [-40 °F ... +176 °F]
Material	Standard V2A V4A DIN 1.4305 DIN 1.4404 AISI 303 AISI 316L shaft/hollow shaft V2A V2A V4A flange aluminum V2A V4A housing aluminum V2A V4A
Shock resistance acc. EN 60068-2-27	2500 m/s ² , 6 ms
Vibration resistance acc. EN 60068-2-6	100 m/s ² , 55 ... 2000 Hz

Electrical characteristics	
Supply voltage	10 ... 30 V DC
Power consumption (no load)	max. 250 mA
Reverse polarity protection of the supply voltage (+V)	yes

Approvals	
UL compliant in accordance with	File no. E224618
CE compliant in accordance with	EMC Directive 2014/30/EU RoHS Directive 2011/65/EU
UKCA compliant in accordance with	EMC Regulations S.I. 2016/1091 RoHS Regulations S.I. 2012/3032

Interface characteristics PROFINET IO

General information	
Protocol	PROFINET IO
Classifications	RT Class 3 (IRT) Conformance Class C Application Class 6 Encoder Class 4 Netload Class III

Adjustable parameters	
<ul style="list-style-type: none"> • Preset • Counting direction • Resolution per revolution - MUR • Unit speed • IP address • Total resolution - TMR • Position format • Speed reference value 	<ul style="list-style-type: none"> • Scaling • Device name • F-Destination Address • I&M 0...3 Parameter • Alarm behavior • Parameter write protection • Parameter initialization

Resolution	
Resolution singleturn (MUR)	scalable 1 ... 524 288 (19 bit) default 8192 (13 bit)
Number of revolutions (NDR)	1 ... 16 777 216 (24 bit) scalable only via the total resolution
Total resolution (TMR)	scalable 1 ... 8 796 093 022 208 (43 bit) default 33 554 432 (25 bit)



PROFINET characteristics	
<ul style="list-style-type: none"> • I&M 0 ... 3 • standard telegrams (81, 82, 83, 84, 86, 88) • IRT up to 250 µs • RT Safe up to 4 ms 	<ul style="list-style-type: none"> • MRP • LLDP • PDEV • SNMP • FSU

Process data	
<ul style="list-style-type: none"> • Position • Speed 	<ul style="list-style-type: none"> • Failure • Warnings

Absolute encoders – multiturn

Standard electronic multiturn, optical	Sendix F5868 / F5888 (shaft / hollow shaft)	PROFINET IO
---	--	--------------------

Terminal assignment bus

Interface	Type of connection	Function	M12 connector, 4-pin					
C	N (3 x M12 connector)	Bus Port 1	Signal:	Transmit data+	Receive data+	Transmit data -	Receive data -	 D coded
			Abbreviation:	TxD+	RxD+	TxD-	RxD-	
			Pin:	1	2	3	4	
		Power supply	Signal:	Voltage +	–	Voltage –	–	 D coded
			Abbreviation:	+ V	–	0 V	–	
			Pin:	1	2	3	4	
		Bus Port 2	Signal:	Transmit data+	Receive data+	Transmit data -	Receive data -	 D coded
			Abbreviation:	TxD+	RxD+	TxD-	RxD-	
			Pin:	1	2	3	4	

Rear side connections and display elements

①	Ethernet Port – Link 2	
②	Supply voltage	
③	Cover screw	
④	Ethernet Port – Link 1	
⑤	Link 2	flashes yellow when connected
⑥	BF – Bus Failure	displays network errors *)
⑦	SF – System Failure	displays system errors *)
⑧	ENC	shows status of encoder *)
⑨	Link 1	flashes yellow when connected

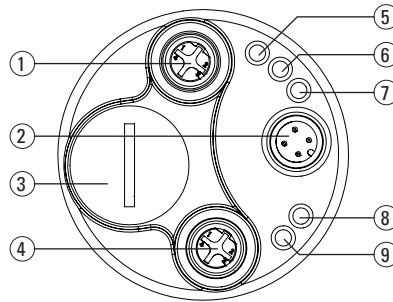

*) see manual

**Standard
electronic multiturn, optical**

Sendix F5868 / F5888 (shaft / hollow shaft)

PROFINET IO

Technology in detail

Clock synchronicity – Isochronous Real Time (IRT) in position sensor technology

In general, for time-critical applications, focus is set on very short sensor cycle times. However, in order to achieve high control performance, simply accelerating data acquisition and processing by shortest cycle times is not sufficient. All sensors and actuators are to operate according to the same clock.

This is achieved thanks to a clock used for the whole network, defined by the controller. This transmit clock cycle (IRT clock) is however not necessarily the clock cycle used for process data exchange. Another cycle (application cycle) is used for this purpose, which can also be defined by the customer controller. The illustration below represents the connection between the different clock cycles.

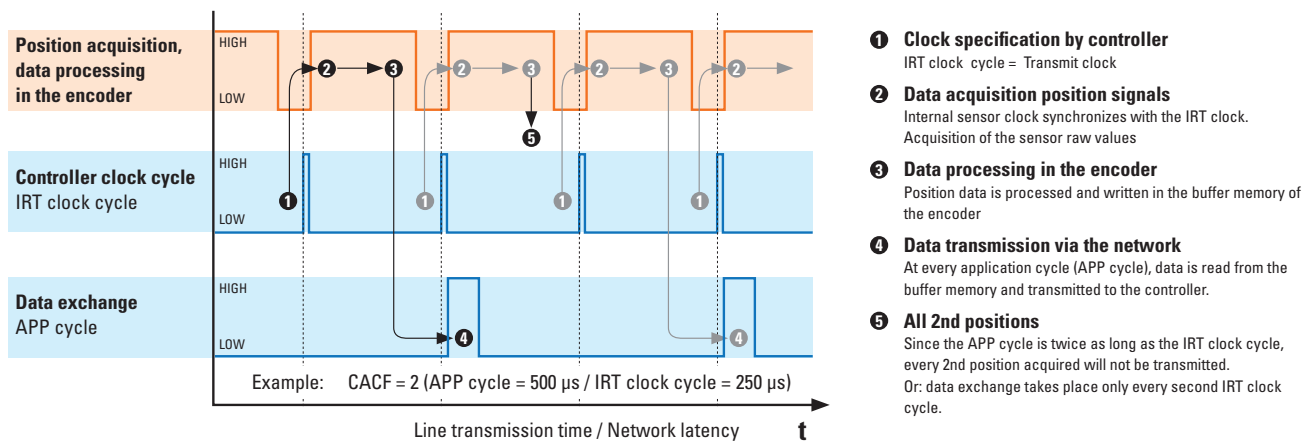

When receiving the IRT clock signal, the sensor starts reading its current measured point. This raw value is processed internally (e.g. scaling, speed calculation, etc.) and stored in a buffer memory.

The buffer memory is read at every application cycle. If it contains a value, this value is transmitted to the controller via the network.

If the application cycle is a multiple of the IRT clock cycle, it may happen that the buffered process data is not sent directly, but is overwritten, because, even though this data is acquired with every IRT clock cycle, it is sent only with every application cycle.

The ratio between application cycle and IRT clock cycle represents the CACF (Controller Application Cycle Factor).

In this example, the $CACF = 2$. This indicates that only every 2nd acquired position will be transmitted to the controller.

The described methodology guarantees a determinism: since the controller defines a clock cycle for the whole network, this allows ensuring that all measured values transmitted by the sensors to the controller are never older than the selected IRT cycle! Therefore, all downstream actuators can always be regulated on the basis of the latest available measured values.

Absolute encoders – multiturn

Standard electronic multiturn, optical	Sendix F5868 / F5888 (shaft / hollow shaft)	PROFINET IO
---	--	--------------------

Dimensions shaft version

Dimensions in mm [inch]

Clamping flange, ø 58 [2.28]

Flange type 1 + 3

- 1 3 x M3, 6 [0.24] deep
- 2 3 x M4, 8 [0.31] deep

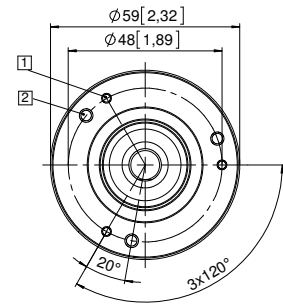
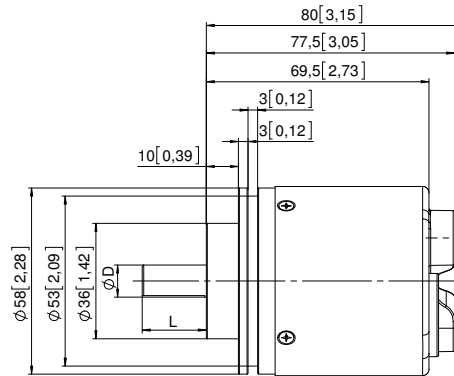

D	Fit	L
6 [0.24]	h7	10 [0.39]
10 [0.39]	f7	20 [0.79]
1/4"	h7	7/8"
3/8"	h7	7/8"

Synchro flange, ø 58 [2.28]

Flange type 2 + 4

- 1 3 x M3, 6 [0.24] deep

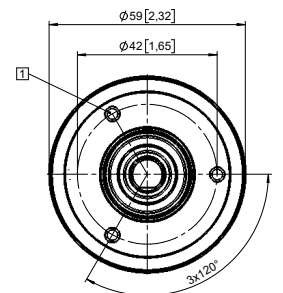
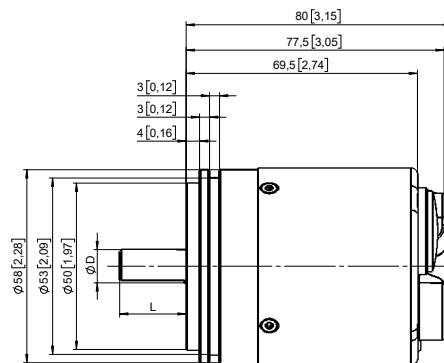

D	Fit	L
6 [0.24]	h7	10 [0.39]
10 [0.39]	f7	20 [0.79]
1/4"	h7	7/8"
3/8"	h7	7/8"

Square flange, □ 63.5 [2.5]

Flange type 5 + 7

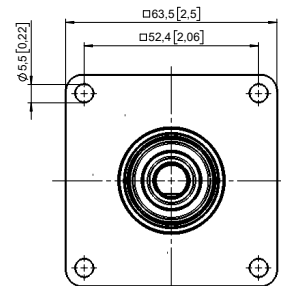
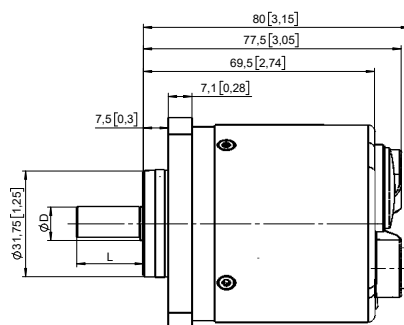

D	Fit	L
6 [0.24]	h7	10 [0.39]
10 [0.39]	f7	20 [0.79]
1/4"	h7	7/8"
3/8"	h7	7/8"

Absolute encoders – multiturn

Standard electronic multiturn, optical

Sendix F5868 / F5888 (shaft / hollow shaft)

PROFINET IO

Dimensions hollow shaft version

Dimensions in mm [inch]

Flange with spring element, long

Flange type 1 + 2

- 1 Slot spring element, recommendation: torque pin DIN 7, \varnothing 4 [0.16]
- 2 3 x M3, 5.5 [0.22] deep
- 3 Recommended torque for the clamping ring 0.6 Nm

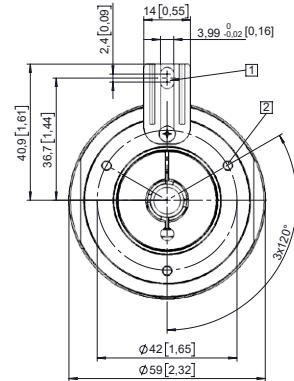
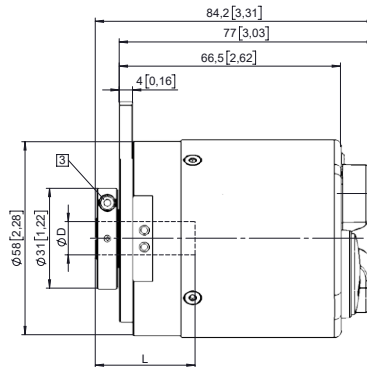

D	Fit	L
10 [0.39]	H7	30 [1.18]
12 [0.47]	H7	30 [1.18]
14 [0.55]	H7	30 [1.18]
15 [0.59]	H7	30 [1.18]
3/8"	H7	30 [1.18]
1/2"	H7	30 [1.18]

L = insertion depth max. blind hollow shaft

Flange with stator coupling, \varnothing 65 [2.56]

Flange type 3 + 4

- 1 Recommended torque for the clamping ring 0.6 Nm

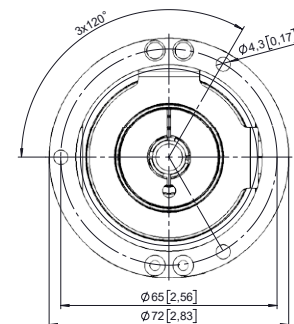
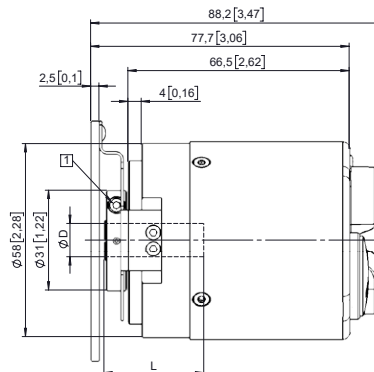

D	Fit	L
10 [0.39]	H7	30 [1.18]
12 [0.47]	H7	30 [1.18]
14 [0.55]	H7	30 [1.18]
15 [0.59]	H7	30 [1.18]
3/8"	H7	30 [1.18]
1/2"	H7	30 [1.18]

L = insertion depth max. blind hollow shaft

Flange with stator coupling, \varnothing 63 [2.48]

Flange type 5 + 6

- 1 Recommended torque for the clamping ring 0.6 Nm

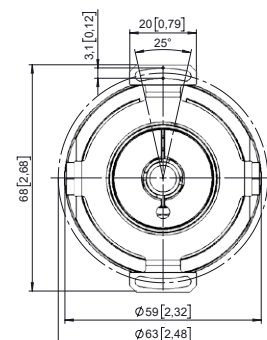
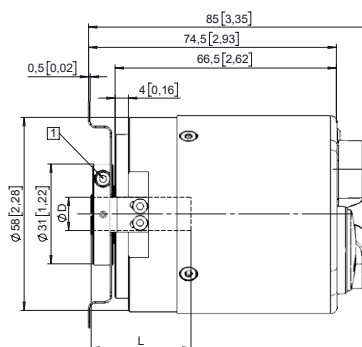

D	Fit	L
10 [0.39]	H7	30 [1.18]
12 [0.47]	H7	30 [1.18]
14 [0.55]	H7	30 [1.18]
15 [0.59]	H7	30 [1.18]
3/8"	H7	30 [1.18]
1/2"	H7	30 [1.18]

L = insertion depth max. blind hollow shaft

Absolute encoders – multiturn

Standard electronic multiturn, optical	Sendix F5868 / F5888 (shaft / hollow shaft)	PROFINET IO
---	--	--------------------

Dimensions hollow shaft version

Dimensions in mm [inch]

**Flange with torque stop, flexible
Flange type 9 + J**

1 Recommended torque for the clamping ring 0.6 Nm

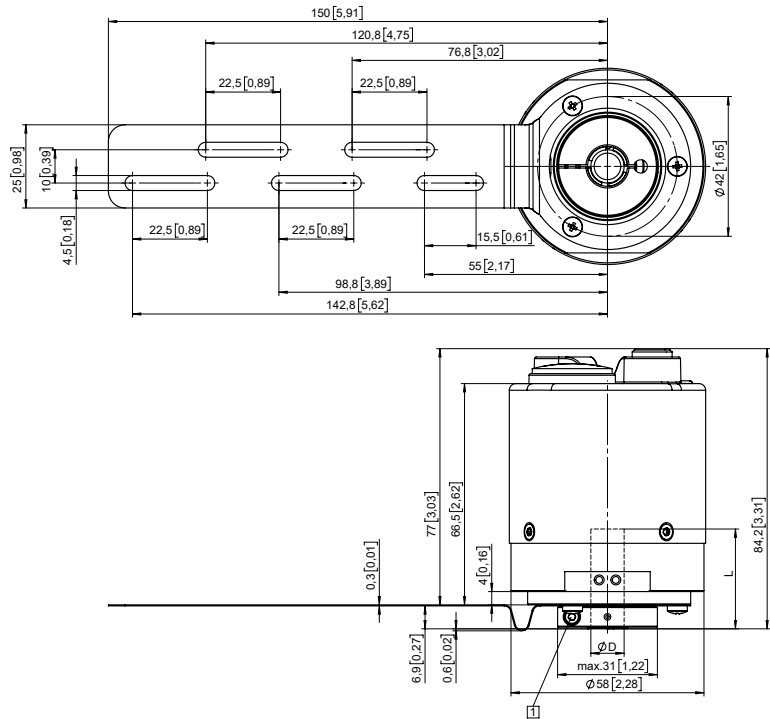

D	Fit	L
10 [0.39]	H7	30 [1.18]
12 [0.47]	H7	30 [1.18]
14 [0.55]	H7	30 [1.18]
15 [0.59]	H7	30 [1.18]
3/8"	H7	30 [1.18]
1/2"	H7	30 [1.18]

L = insertion depth max. blind hollow shaft