

Linear Measuring Technology

Draw wire mechanics with encoder or analogue sensor

Draw wire encoder B80



Wide temperature range



Shock/vibration resistant



High IP protection rating



Reverse polarity protection

Robust

- **Insensitive to the environment**
Titanium-anodised aluminium housing
- **High-resistance wire**
Stainless steel wire
- **Wire exit free from wear**
Diamond-polished ceramic guide
- **Can be used in a wide temperature range without extra charge**
max. -20 ... +90 °C



Dynamic

- **High traverse speed**
- **High acceleration**
Dynamic spring traction by means of a constant force spring, long service life, approx. 2 million complete cycles

Versatile

- **Suitable for various sensors/encoders**
 - Absolute
 - Fieldbus
 - Incremental
 - Analogue
- **Quick mounting**
Fastening by means of 2 screws
- **Flexible connection possibilities**
Cable, connector, radial, axial
- **Linearity up to 0.05 %**

Mechanical characteristics (draw wire mechanics):

Measuring range:	1000 mm	2000 mm	3000 mm
Extension force Fmin:	5.4 N	5.4 N	5.4 N
Fmax:	6.6 N	7.8 N	9.1 N
Max. speed:	10 m/s	10 m/s	10 m/s
Max. acceleration:	140 m/s ²	140 m/s ²	140 m/s ²
Linearity:	analogue output: 0.1 % (of the measuring range) encoder: 0.05 % (of the measuring range)		
Weight:	approx. 750 g (depending on the sensor/encoder used)		
Materials:	housing: titanium-anodised aluminium wire: stainless steel ø 0.5 mm		
Protection (sensor):	IP65 (IP67 on request for encoders)		
Lifetime	> 2 million full cycles		

Operating principle:

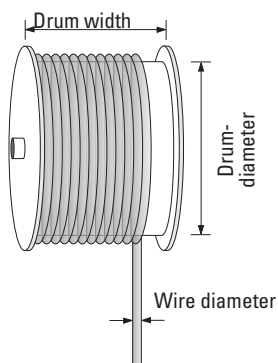

Construction:

The core of a draw wire device is a drum mounted on bearings, onto which a wire is wound. Winding takes place via a spring-loaded device.

Note

Exceeding the maximum extension length of the draw wire will lead to damage to the wire and the mechanics.

Linear Measuring Technology

Draw wire mechanics with encoder or analogue sensor

Draw wire encoder B80

Electrical characteristics (digital output):

The electrical characteristics of the draw wire mechanics with digital output can be found in the data sheets of the encoders.

Electrical characteristics (analogue output):

Analogue output:	0 ... 10 V	4 ... 20 mA	Potentiometer
Output:	0 ... 10 V galvanically isolated, 4 conductors	4 ... 20 mA 2 conductors	1 kOhm
Supply voltage:	12 ... 30 V DC	12 ... 30 V DC	max. 30 V DC
Recommended slider current:	–	–	< 1 µA
Max. current consumption:	22.5 mA (no load)	50 mA	–
Reverse polarity protection:	yes	yes	–
Operating temperature:	-20 ... +60 °C	-20 ... +60 °C	-20 ... +85 °C

Connection diagrams:

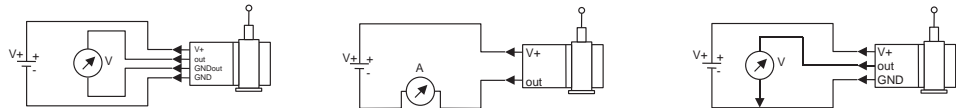

CE compliant according to: EN 61000-6-2, EN 61000-6-4, EN 61000-6-3

Terminal assignment (analogue output):

Pin	Cable colour	0 ... 10 V	4 ... 20 mA	1 kOhm
1	brown	V+	V+	V+
2	white	Signal	n. c.	Slider
3	blue	GND	Signal	GND
4	black	GND Sig.	n. c.	n. c.

Connector (analogue output):

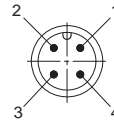

Dimensions:

Draw wire mechanics with encoder

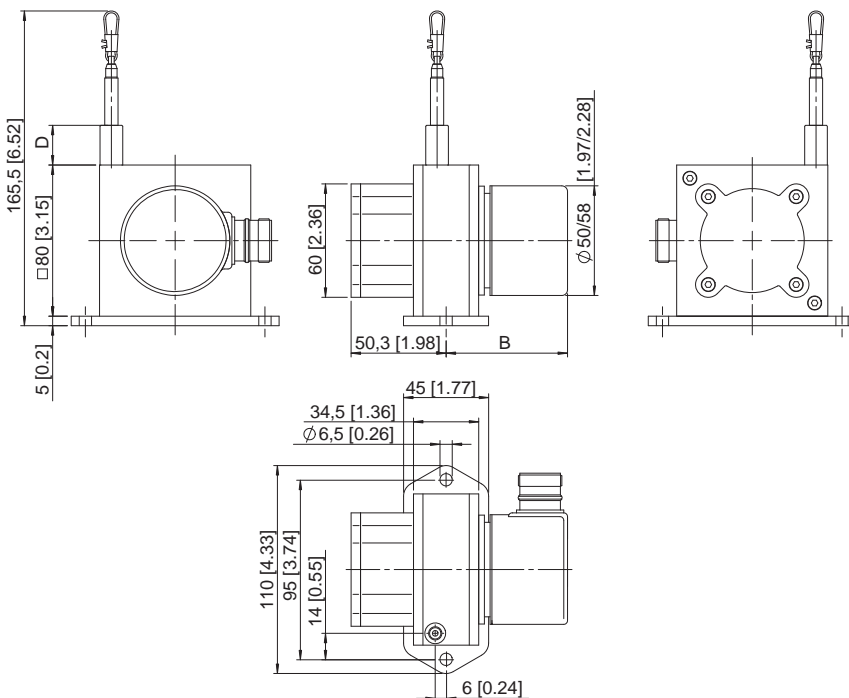

Measuring range [mm]	D
1000	21
2000	35
3000	35

Dimension B depends on the encoder used	
Encoder	B
Sendix incremental (5000) D8.4B1.XXXX.00XX.XXXX	54.25
Sendix absolut (5863) D8.4B1.XXXX.63XX.XXXX	66.75
Sendix absolut (5868) D8.4B1.XXXX.68XX.XXXX	93.25

Linear Measuring Technology

Draw wire mechanics with encoder or analogue sensor

Draw wire encoder B80

Order code with encoder:

D8.4B1.XXXX.XXXX.XXXX

Draw wire mechanics

Measuring range*

0100 = 1000 mm

0200 = 2000 mm

0300 = 3000 mm

*other measuring ranges on request

Resolution/protocol/options
depending on the encoder used

Type of connection: *
depending on the encoder used

Output: *
depending on the encoder used

Encoder used*
00 = Sendix incremental 5000
63 = Sendix absolut 5863
68 = Sendix absolut 5868

*You will find our recommended encoders below

Standard resolutions for draw wire with incremental encoder Sendix 5000, drum circumference 200 mm			
Pulses/revolution	200	2000	4000
Pulse/mm	1	10	20
Resolution [mm]	1	0.1	0.05

Standard resolutions for draw wire with absolute encoder Sendix 5863 or 5868, drum circumference 200 mm		
Absolute encoder	5863	5868
Pulse/revolution	2048/11 bits	4096, programmable via the bus/ 12 bits
Pulse/mm	10.24	20.48
Resolution [mm]	~0.1	~0.05

Recommended standard device
with **incremental** encoder
Sendix 5000:

D8.4B1.XXXX.0053.2000

The standard device is supplied mounted. The mounted encoder is the Sendix incremental 5000 encoder, Connector axial 8 pin M12, Push-pull with inverted signals, supply voltage 10 ... 30 V DC (8.5000.8353.2000)

Recommended standard device
with **absolute** encoder
Sendix 5863 or 5868:

D8.4B1.XXXX.6324.G123

Sendix absolut **5863** encoder with **SSI interface** (Gray code), 2048 pulses/rev., Set key, 10 ... 30 V DC, radial 12 pole M23 connector (8.5863.1224.G123)

D8.4B1.XXXX.6822.2113

Sendix absolut **5868** encoder with **CANopen interface**, 4096 pulses/rev. programmable via the bus, Set key, 10 ... 30 V DC, M12 connector (8.5868.1222.2113)

D8.4B1.XXXX.6832.3113

Sendix absolut **5868** encoder with **Profibus connection**, 4096 pulses/rev. programmable via the bus, Set key, 10 ... 30 V DC, M12 connector (8.5868.1232.3113)

Measuring range

0100 = 1000 mm

0200 = 2000 mm

0300 = 3000 mm

*other measuring ranges on request

Linear Measuring Technology

Draw wire mechanics with encoder or analogue sensor

Draw wire encoder B80

Dimensions:
Draw wire mechanics with analogue sensor

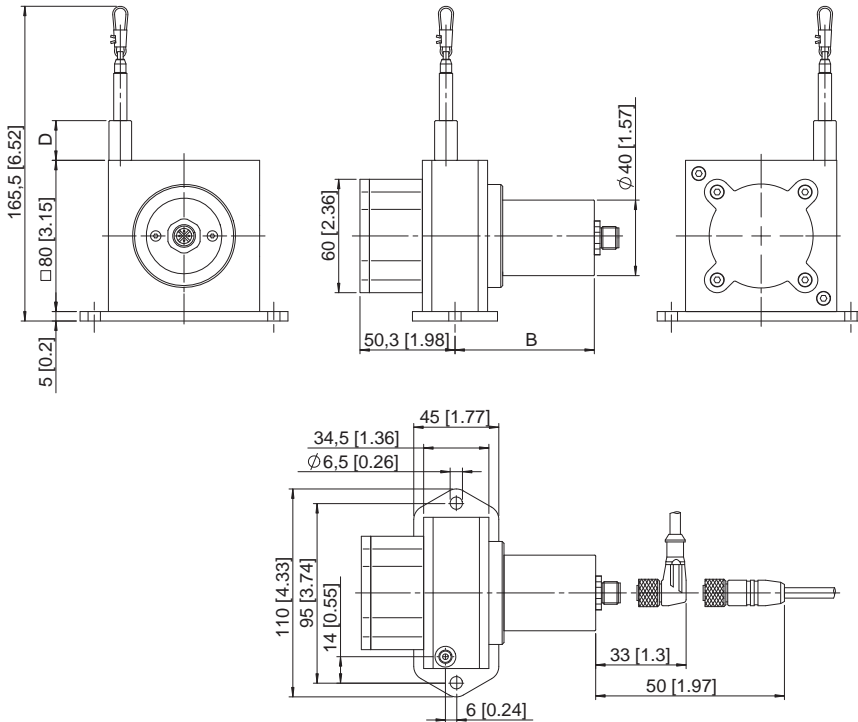

Sensor type	Measuring length [mm]	B	D
Potentiometer	1000	74	21
	2000		
	3000	102.25	35
0 ... 10 V 4 ... 20 mA	1000	87.5	21
	2000		
	3000	102.25	35

Order code with analogue sensor:

D8.3B1.XXXX.XXXX.0000

<p>Draw wire mechanics</p> <p>Measuring range*</p> <p>0100 = 1000 mm</p> <p>0200 = 2000 mm</p> <p>0300 = 3000 mm</p> <p>*other measuring ranges on request</p>	<p>Type of connection:</p> <p>1 = Axial cable, length 2m</p> <p>3 = 4-pole M12 connector</p>
<p>Analogue sensor output</p> <p>A11 = 4 ... 20 mA Supply voltage 12 ... 30 V DC</p> <p>A22 = 0 ... 10 V Supply voltage 12 ... 30 V DC</p> <p>A33 = Potentiometer 1 kOhm Max. supply voltage 30 V DC</p>	

Accessories:
Guide pulley for draw-wire encoder



Order code for the set:
(Guide pulley, 2x countersunk screws for lateral fixing, 2x hexagonal screws for fixing on a flat surface)
8.0000.7000.0045

